

4' - 600-Gallon Single-Wall Oil/Water Separator

A. Use Parameters

Proper performance of the separator and the quality of effluent is based upon the operational, functional and installation requirements, and limitations as detailed in the following Xerxes publications (available from Xerxes):

1. Oil/Water Separator Product Literature;
2. Underground Storage Tank Installation Manual and Operating Guidelines;
3. Oil/Water Separator Installation, Operation and Maintenance Manual.

B. Design Parameters

This separator is designed for:

1. maximum influent quality _____ ppm,
2. maximum flow rate _____ gpm,
3. number of coalescer rows to be installed _____.

The undersigned acknowledges and agrees to the use and design parameters as detailed on this drawing and in the referenced publications and hereby approves fabrication. Any deviation from these parameters and limitations, as outlined in "A. Use Parameters" above, must be approved by Xerxes in writing prior to the start of manufacture.

Signature

Printed Name

Date

Company

Project

Symbol Identification

- A. * Dia. FRP Influent Flanged Nozzle with Diffuser
- B. * Dia. FRP Effluent Flanged Nozzle with Clean-Water Outlet
- C. 22" Dia. Manway with 24" High FRP Extension, 4-4" NPTs in Cover & 4-12"x12"x12ga. Gauge Plates
- D. Platform, Sludge Baffle & Coalescer
- E. Lifting Lug (2 required)
- ▶ Hold-down Strap Location

* See Oil/Water Separator Product Literature to identify proper pipe/flange size, which is determined by selected flow rate.

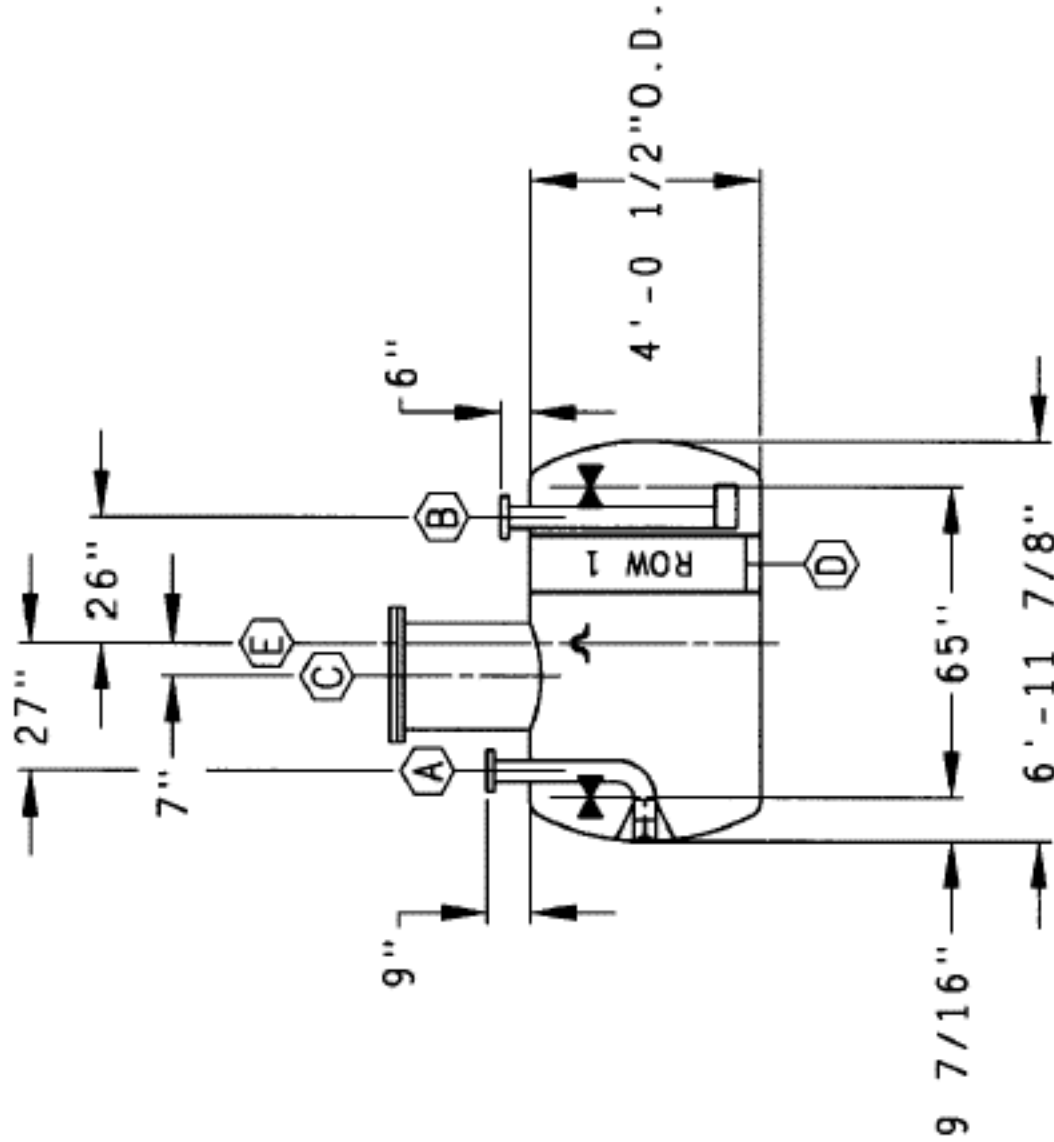
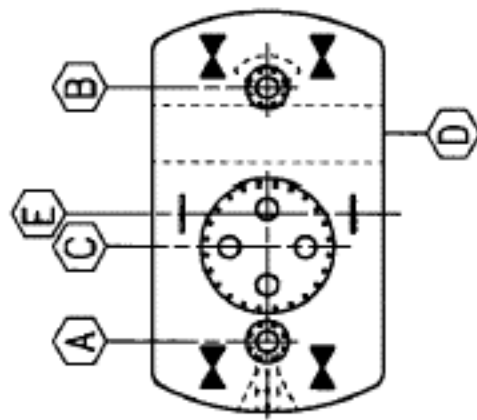

XERXES[®]

CORPORATION

Max. Effluent Quality

10 ppm

Max. Spill Capacity

360 gal.

Nominal Weight

800 lb.